

 **Romway**<sup>®</sup>  
—LEADING INNOVATION—

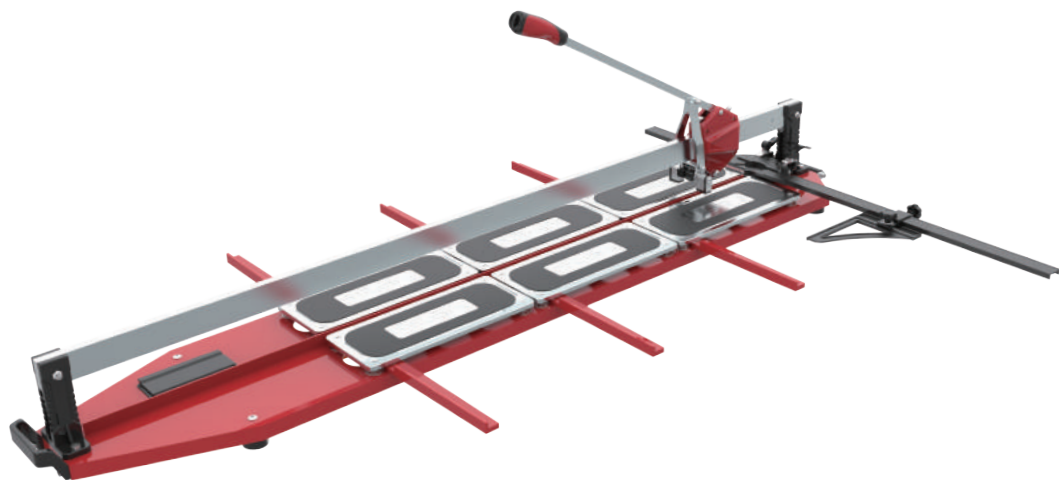





540951-1350

[www.romway.eu](http://www.romway.eu)

**EN**

We thank you for having chosen one of our tile cutters. These robust and reliable machines have been designed to respond to your needs.

**WARNING**





-  Please read this manual carefully before use.
  -  The manufacturer accepts no responsibility in the event that this tile cutter would be used in combination with other tools, or to cut any material other than tiles.
  -  The machine must only be used in a horizontal position.
  -  Loosen the carriage locking screw before use.
- It is necessary to lock the carriage again if the machine is to be moved.

NB: The photos and sketches presented in this manual are non-contractual, the characteristics of the machine could be modified without prior warning.

**DE-**

Wir danken Ihnen für Ihr Vertrauen in unsere Fliesenschneidmaschinen. Sie sind robust und zuverlässig und wurden konzipiert, um Ihre Erfordernisse zu erfüllen.

**WARNUNG**





-  Bitte lesen Sie diese Anleitung vor Gebrauch sorgfältig durch.
  -  Der Hersteller übernimmt keine Verantwortung für den Fall, dass diese Fliesenschneidmaschine in Kombination mit anderen Werkzeugen, oder zum Schneiden von anderen Materialien als Fliesen eingesetzt würde.
  -  Die Maschine darf nur in horizontaler Lage betrieben werden.
  -  Lösen Sie vor Gebrauch die Feststellschraube des Schneidkopfes.
- Es ist notwendig, den Schneidkopf wieder zu verriegeln, wenn die Maschine bewegt werden soll.

NB: Die in diesem Handbuch verwendeten Fotos und Skizzen sind nicht vertraglich, die Kenndaten der Maschine können jederzeit unangekündigt geändert werden.

**FR-**

Nous vous remercions d'avoir choisi une de nos machines coupe-carreaux. Celles-ci, robustes et fiables, sont conçues pour répondre à vos besoins.

**AVERTISSEMENT**





-  Prière de lire attentivement ce manuel avant utilisation.
  -  Le fabricant n'accepte aucune responsabilité dans le cas où cette machine coupe-carreaux serait utilisée en combinaison avec d'autres outils, ou pour couper tout matériau autre que du carrelage.
  -  La machine doit être utilisée en position horizontale exclusivement.
  -  Desserrer la vis de blocage du chariot avant utilisation.
- Il est nécessaire de bloquer à nouveau le chariot dans le cas où la machine doit être déplacée.

NB : Les photos et croquis présents dans cette notice ne sont pas contractuels, les caractéristiques de la machine pouvant être modifiées sans préavis.

**NL-**

U hebt één van onze tegelsnijders aangeschaft en wij danken u voor uw vertrouwen. Onze machines zijn robuust en bedrijfszeker en ze zijn ontworpen om aan uw behoeften te voldoen.

**WAARSCHUWING**





-  Lees deze handleiding zorgvuldig vóór gebruik.
  -  De fabrikant aanvaardt geen enkele verantwoordelijkheid in het geval dat deze tegelsnijder wordt gebruikt in combinatie met ander gereedschap, of om ander materiaal dan tegels te snijden.
  -  De tegelsnijder mag alleen in horizontale positie worden gebruikt.
  -  Draai de borgschroef van de zaagkop los voor gebruik.
- Voor het verplaatsen van de machine is het noodzakelijk om de zaagkop weer te vergrendelen.

NB: Aan de foto's en illustraties getoond in deze handleiding kunnen geen rechten ontleend worden aangezien de eigenschappen van de machine zonder voorafgaande mededeling gewijzigd kunnen worden.

**ES-**

Le agradecemos que haya elegido uno de nuestros cortadores de azulejos. Nuestro material es robusto y fiable, y se ha concebido para responder a sus necesidades.

**AVERTIZACIÓN**





-  Por favor, lea atentamente este manual antes de utilizar la máquina.
  -  El fabricante no se hace responsable en caso de que esta máquina cortadora de azulejos y baldosas se usará en combinación con otras herramientas, o para cortar cualquier material que no sea azulejos.
  -  La máquina sólo debe utilizarse en posición horizontal.
  -  Afloje el tornillo de bloqueo del carro antes de usarlo.
- Es necesario bloquear de nuevo el carro si se va a mover la máquina.

NB: Las fotografías y croquis de este manual no son contractuales, las características de la máquina pueden modificarse sin preaviso.

**IT-**

Vi ringraziamo per aver scelto una delle nostre tagliapiastrelle. Sono robusti e affidabili e sono stati progettati per soddisfare le vostre esigenze.

**ATTENZIONE**





-  Si prega di leggere attentamente questo manuale prima dell'uso.
  -  Il produttore non si assume alcuna responsabilità nel caso in cui questa macchina tagliapiastrelle sarebbe stata usata in combinazione con altri utensili, o per tagliare qualsiasi materiale diverso dalle piastrelle.
  -  La macchina deve essere utilizzata solo in posizione orizzontale.
  -  Allentare la vite di bloccaggio del carrello prima dell'uso.
- Per spostare la macchina è necessario bloccare nuovamente il carrello.

NB: Le illustrazioni e gli schizzi inseriti in questo documento non hanno valore contrattuale, le caratteristiche della macchina possono essere modificate senza preavviso.

**PT-**

Agradecemos-lhe o facto de ter escolhido uma das nossas máquinas. Estas, robustas e fiáveis, são concebidas para responderem às suas necessidades.

**AVISO**





-  Por favor, leia este manual cuidadosamente antes de usar.
  -  O fabricante não assume qualquer responsabilidade no caso de esta máquina de cortar azulejos seria usada em combinação com outras ferramentas ou para cortar qualquer material que não seja azulejos.
  -  A máquina só pode ser utilizada na posição horizontal.
  -  Desaperte o parafuso de bloqueio do carro antes da utilização.
- É necessário travar o carro novamente se a máquina for movimentada.

NB: As fotografias e esboços presentes nestas instruções não são contratuais, podendo as características da máquina ser alteradas sem aviso prévio.

**PL-**

Dziękujemy za wybór jednej z naszych maszyn. Te solidne i niezawodne urządzenia zostały zaprojektowane z myślą o zaspokojeniu Państwa potrzeb.

**OSTRZEŻENIE**

-  Przed użyciem należy dokładnie przeczytać niniejszą instrukcję obsługi.
  -  Producent nie ponosi odpowiedzialności w przypadku, gdy frez do płytek będzie używany w połączeniu z innymi narzędziami lub do cięcia innych materiałów niż płytki.
  -  Maszyna może być używana tylko w pozycji poziomej.
  -  Przed użyciem odkręcić śrubę blokującą wózek.
- Jeżeli maszyna ma być przemieszczana, należy ponownie zablokować wózek.

Uwaga: Zdjęcia i szkice przedstawione w niniejszej instrukcji obsługi są zdjęciami i szkicami pozaumownymi, właściwości maszyny mogą być zmieniane bez wcześniejszego ostrzeżenia.

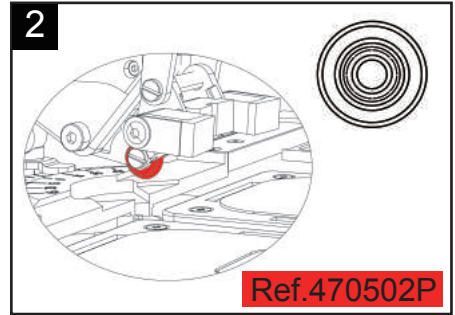
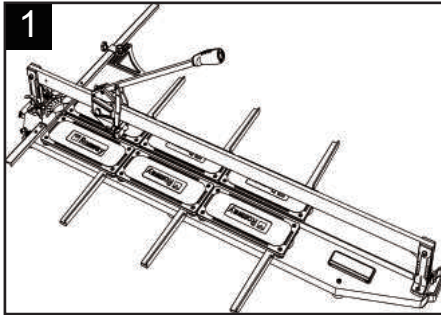

90°

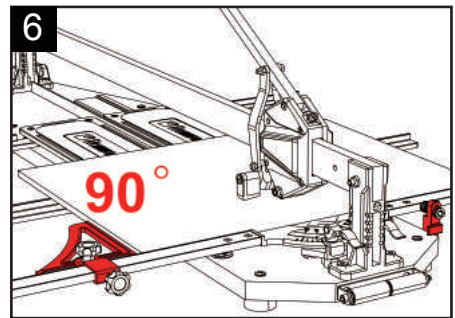
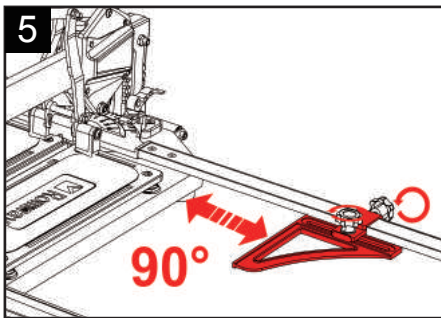
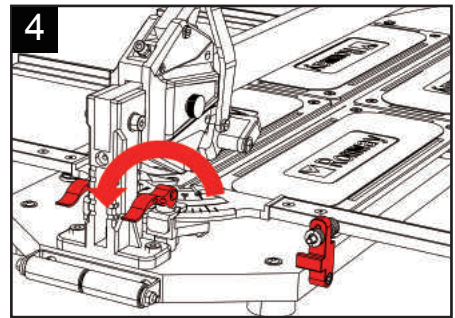
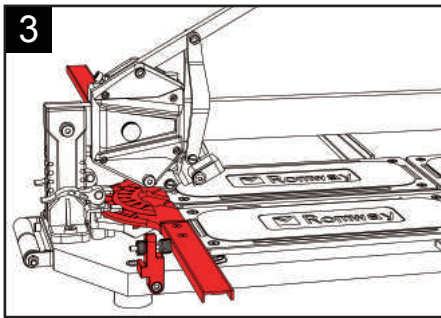

45°

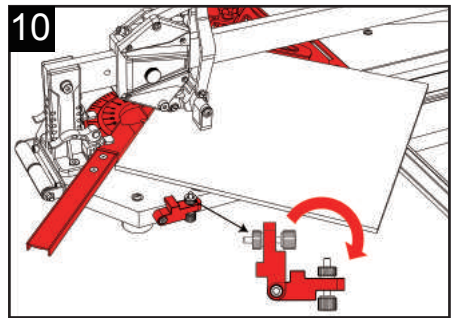
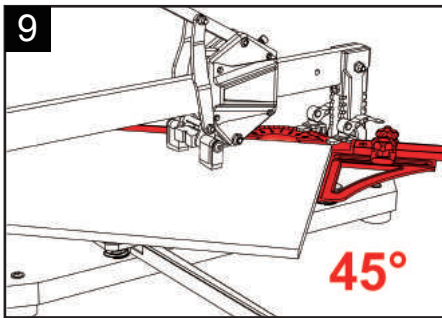
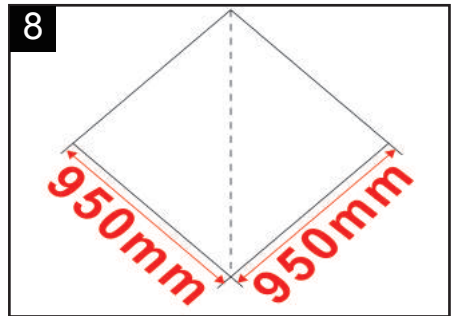
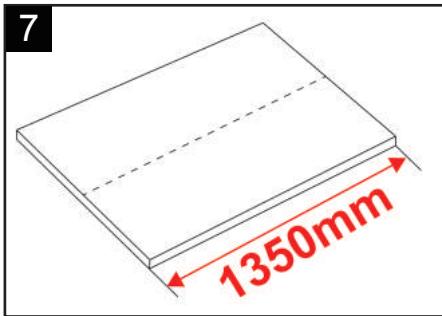

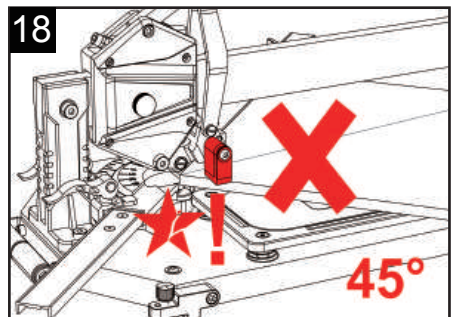
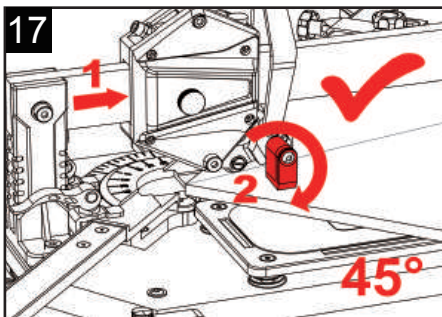
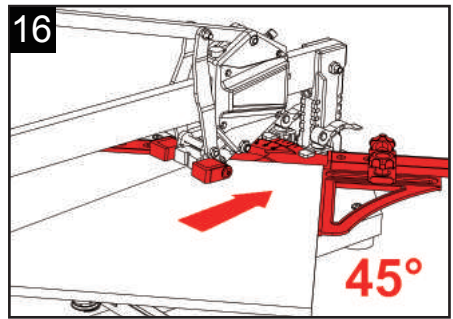
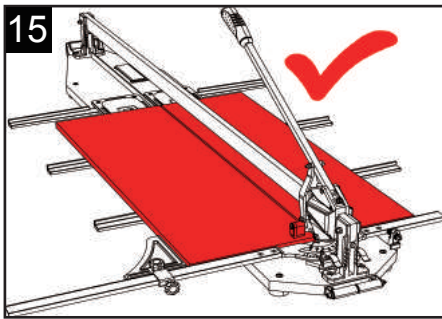
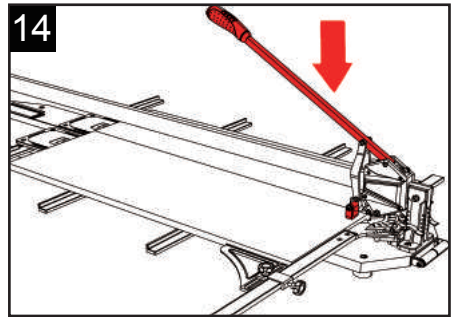
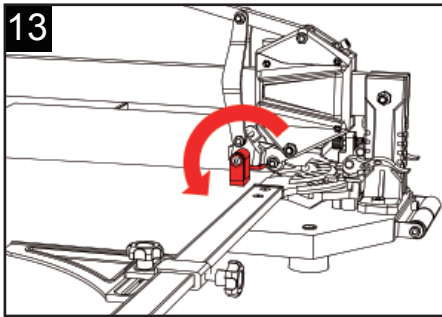
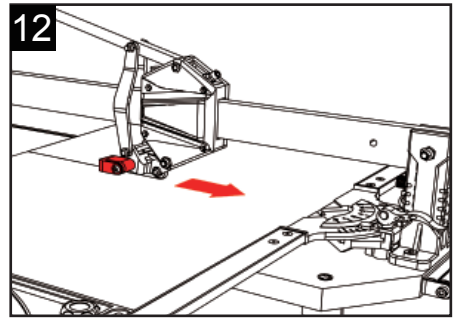
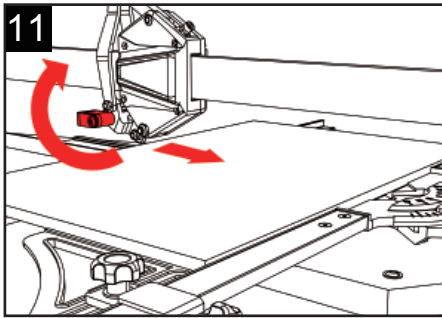

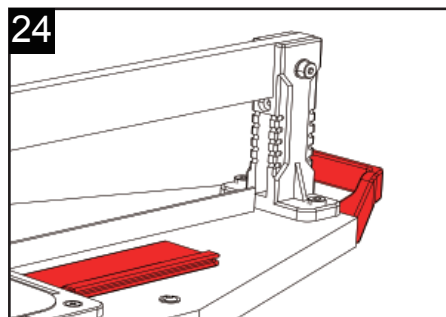
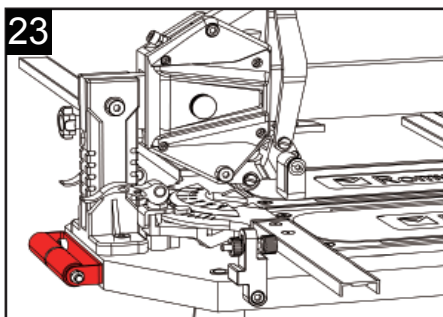
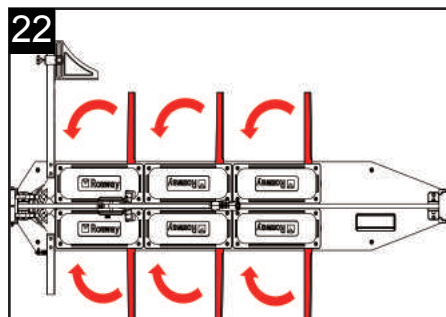
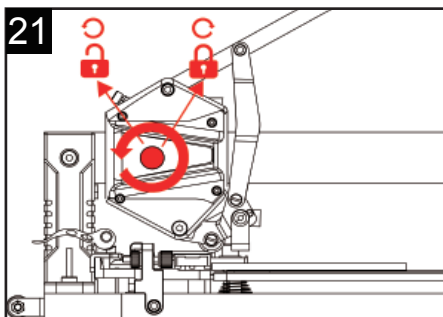
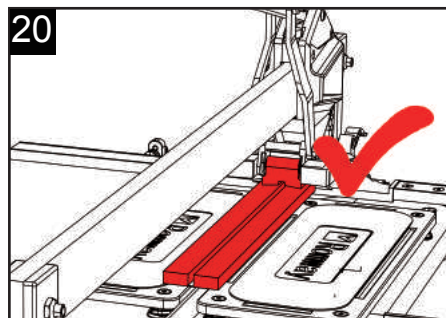
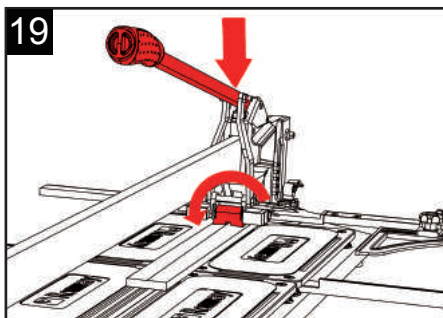

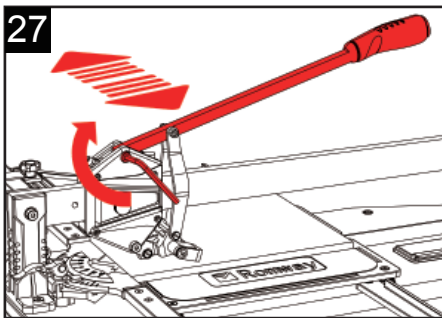
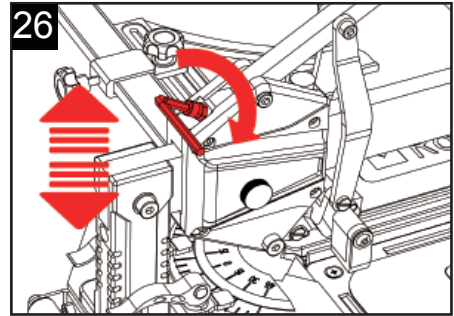
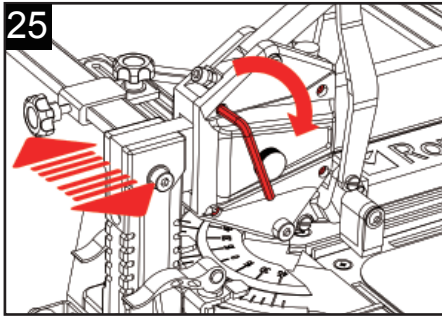



## TECHNICAL DATA

Item No.						
540951-1350	22X6X6(2)mm	1350mm	950*950mm	18mm	1645*335*270mm	24kg

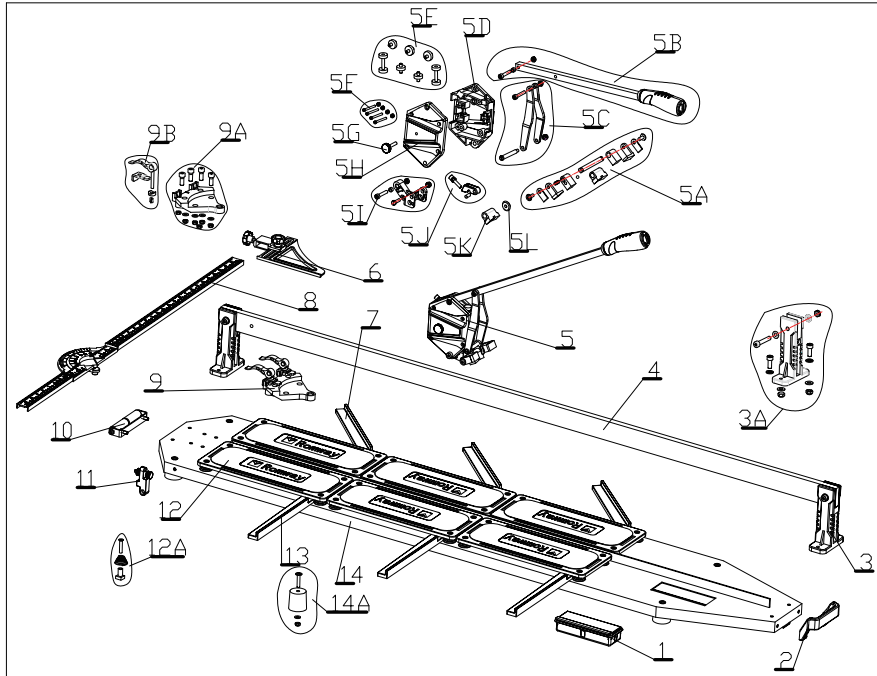

No.	Description	Qty.
1	Tool box	1
2	Transf Handle	1
3	Support	2
3A	Support with screws	2
4	Sliding bar	1
5	Sliding house	1
5A	Breaking Device assemble	1
5B	Push bar	1
5C	Connector assemble	1
5D	Carriage Right side	1
5E	Bearings	1
5F	Bolts	4
5G	Locking Screw	1
5H	Carriage left side	1
5I	Cutting wheel Holder	1
5J	Adjust block	1

No.	Description	Qty.
5K	Small breaker	1
5L	Cutting wheel	1
6	Guide lever assemble	1
7	Right extension bar	3
8	Guide	1
9	Guide holder asseble	1
9A	Guide holder	1
9B	Fast clamp	2
10	Transf wheel	1
11	Angle stop	1
12	Working table	6
12A	Working table fixer	24
13	Left extension bar	3
14	Base	1
14A	Rubber foot	6



—LEADING INNOVATION—

*Head-office:*

**ROMWAY INDUSTRIAL CO.,LTD**

**Add:**1108,Building D, Wanda Plaza,  
Gongshu district, Hangzhou - China

**Tel:**0086-571-88181970 88198770

**Fax:**0086-571-88193125

**E-mail:**romway@romwaytool.com

*Europe:*

**ROMWAY EUROPE SARL**

**Add:**ZI du Casque - 32, rue Aristide Berges  
31270 Cugnaux (Toulouse) - France

**Tel.:** +33 (0)5 34 50 25 02

**Fax:** +33 (0)5 34 50 25 03

**e-mail:** info@romway.eu

[www.romway.eu](http://www.romway.eu)